

# Marvin Bow or Bay Measuring Instructions for an Existing Opening

## Before You Begin

- A qualified bow or bay window installer should review and confirm the measurements and shop drawing prior to placing an order.
  - Numbers listed in parentheses ( ) are metric equivalents in millimeters rounded to the nearest whole number.
  - Remove interior trim and if necessary, trim a section of the interior wall covering to the Rough Opening of the existing window unit as shown in illustration 1.
- IMPORTANT:** Be sure to inspect the existing opening and repair any damage prior to the replacement of your unit.

## Measuring Instructions for Retro Return Marvin Bow or Bay

(For Standard Return Marvin Bow or Bay Measuring Instructions see page 3.)

1. Measure the Rough Opening Height from the interior of the rough opening header to the sill plate. See illustration 1.
2. Measure the Rough Opening Width from jack stud to jack stud. See illustration 2A.
3. Measure the Jamb Depth from interior wall to the exterior sheathing. See illustration 2B.

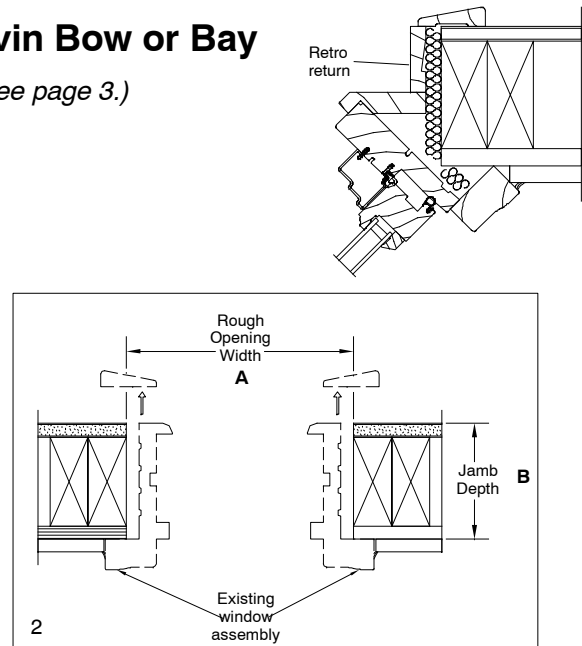
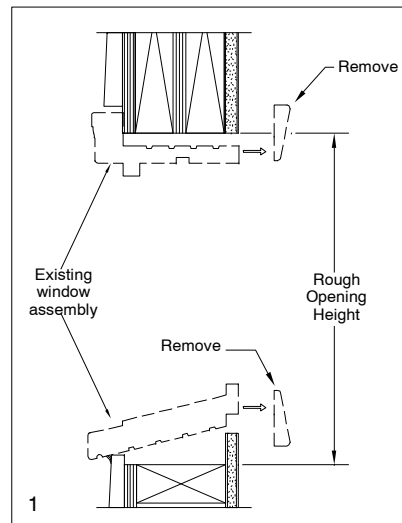

## Installation Suggestions

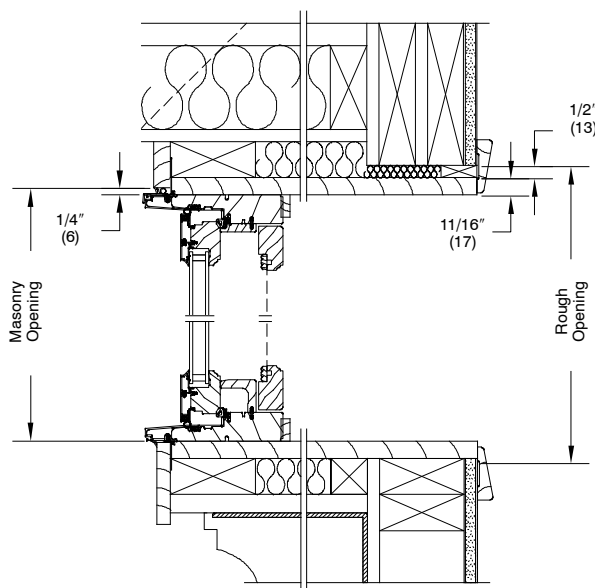

Clad Unit

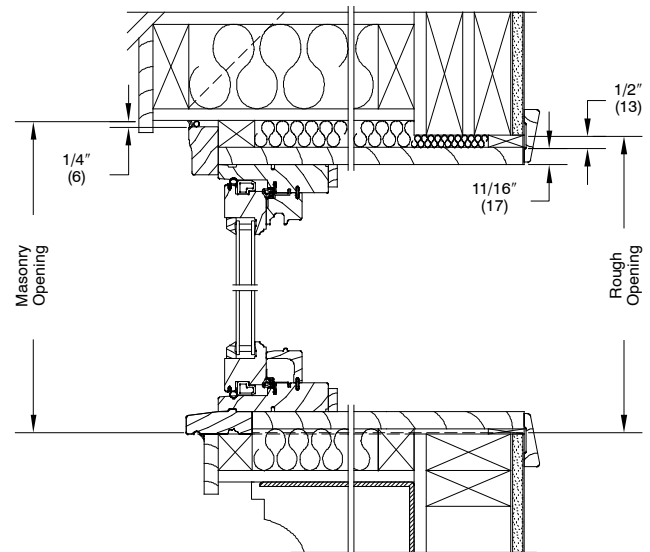

Wood Unit

PROJECT \_\_\_\_\_

MEASURED BY: \_\_\_\_\_

DATE: \_\_\_\_\_

Follow the steps on the previous page to fill in this worksheet.

\* The unit will be fabricated 1" (25) smaller than the R.O. width.

\*\* The unit will be fabricated 1/2" (13) smaller than the R.O. height.

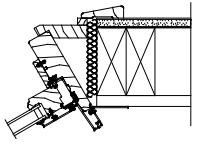
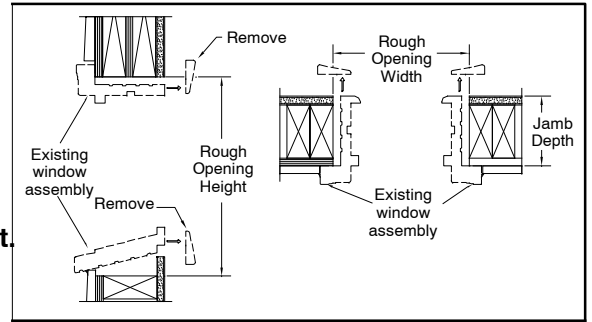

Clad 30°

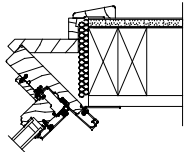

Clad 45°

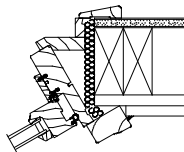

Wood 30°

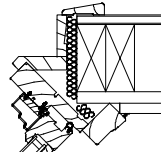

Wood 45°

Product Description	Required Measurements		
Bow or Bay Unit	R.O. Width*	R.O. Height**	Jamb Depth

Provide installation details of existing opening.

- Indicate type and width of exterior casing.
- Type of siding or exterior finish. For example wood siding, stucco or brick.
- Highlight any critical measurement required for installation of the replacement unit

Site Drawing of Existing Opening

A large grid area provided for the user to draw the site drawing of the existing opening. The grid is approximately 20 units wide by 30 units high.

# Measuring Instructions for Standard Return Marvin Bow or Bay

**ATTENTION:** This section is intended to provide a guideline for measuring an existing bow or bay unit to determine if a Standard Return Marvin Bow or Bay unit can be fabricated to fit into the existing opening.

## Required Measurements:

- 1. Rough Opening Width (A)** Measure the straight-line distance between the points where the exterior sheathing ends; record in column A. See illustration 1.
- 2. Masonry Opening Width (B)** Measure the straight-line distance from the exterior of the casing and add 1/2" (13); record in column B. See illustration 1.
- 3. Jamb Depth (C)** Measure the distance from the outside edge of interior and exterior sheathing; record in column C. See illustration 1.

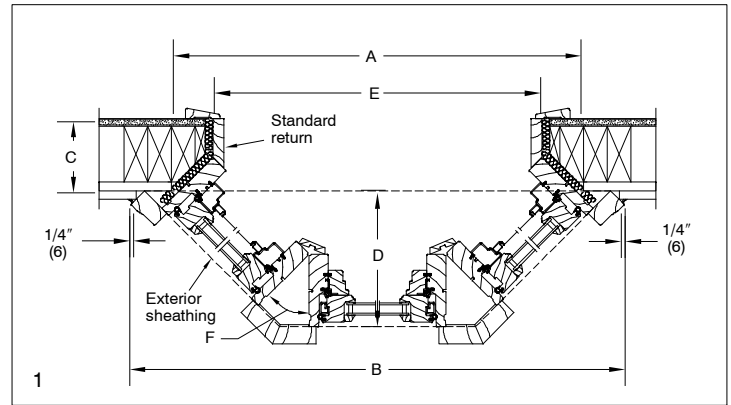

**Wood Unit with BMC**  
Wood siding with 2x4 wood frame construction

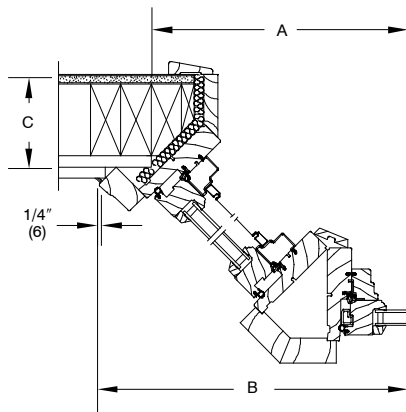

**Clad Unit**  
Wood siding with 2x4 wood frame construction

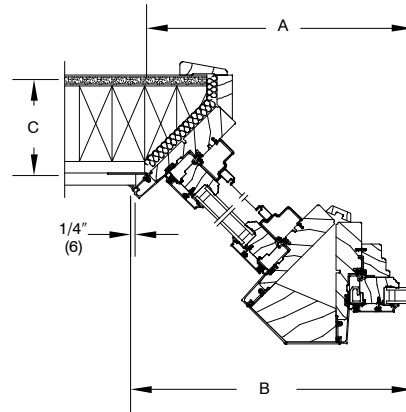

**Wood Unit with BMC**  
Brick Veneer with 2x4 wood frame construction

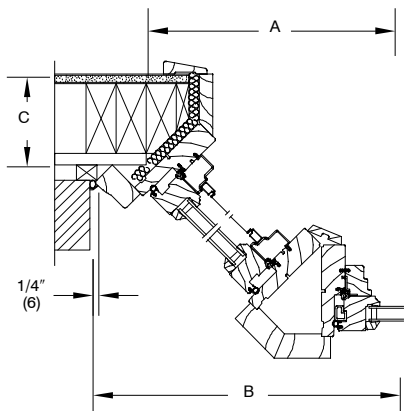

**Clad Unit**  
Brick Veneer with 2x4 wood frame construction

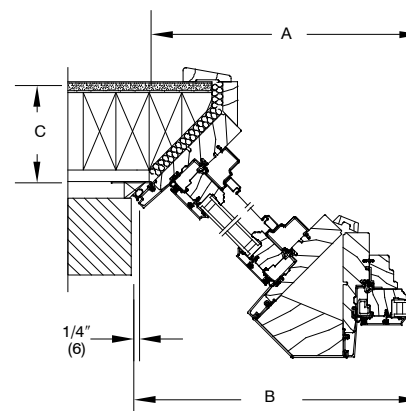

4. **Projection (D)** Measure distance from exterior sheathing at the center of the bow or bay unit to the exterior side of the window frame, or nailing fin kerf; record in column D. See illustration 2.

5. **OSM of Interior Jamb Width (E)** Measure the distance from the exterior edge of the bow to bay jambs; record in column E. See illustration 2.

6. **Angle of Bow or Bay (F)** Measure the angle of the bow or bay window. See illustration 2.

*NOTE: An angle finder can be used to measure the outside angle of the unit. Subtract this angle from 180° to determine unit angle.*

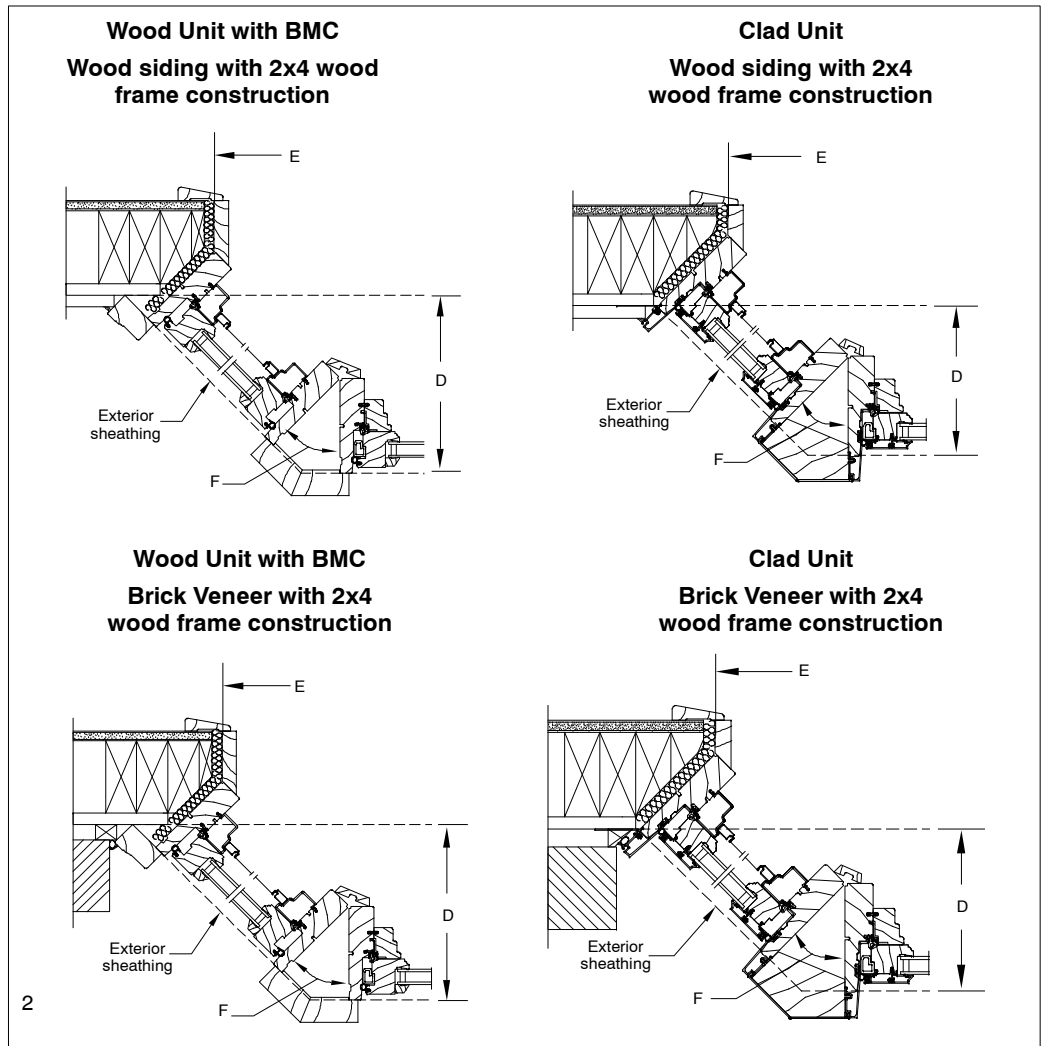

7. **Rough Opening Height (G)** Measure the distance between the sill plate and header; record in column G. See illustration 3.

8. **Masonry Opening Height (H)** Measure from the bottom of sill to the top of exterior casing and add 1/4"; record in column H. See illustration 3.

